

NRG+

LPS & CPS
Catalogue 2025

The logo for exilux, featuring a stylized circular icon composed of horizontal lines to the left of the word "exilux" in a lowercase, sans-serif font.

Our goal is to support clients with systems that perform when it matters most, backed by decades of industry experience and a commitment to excellence.

Contents

Why choose Exilux?	4
How we work, from concept to completion	5
NRG+ LPS	6
NRG+ LPS typical connection diagram	7
NRG+ LPS 230	8
NRG+ LPS 24-230	9
NRG+ LPS 24-230 Li	10
NRG+ LPS 24-230 Li IP66	11
NRG+ CPS	12
NRG+ CPS typical connection diagram	13
NRG+ CPS S28	14
NRG+ CPS B72	15
NRG+ Lithium CPS	16
NRG+ Lithium battery advantages	17
NRG+ CPS M60 Li	18
NRG+ CPS B72 Li	19
NRG+ SUB S	20
NRG+ SUB B	21
NRG+ IOe24	22
NRG+ IOe230-S	23
NRG+ BNW-S	24
NRG+ BNW-5i-S	25
NRG+ ULM addressable module	26
NRG+ PC visualisation software	27
NRG+ Battery monitoring	28
NRG+ / NRG Luminaires	29

Why choose Exilux?

Established in 2025, Exilux is a dynamic new player in the emergency lighting industry, committed to providing cutting-edge, dependable and compliant safety solutions. Based in Scotland, UK, we combine innovation with rigorous engineering to provide state-of-the-art emergency lighting solutions designed to ensure safety and compliance in any environment. Our comprehensive product range includes central battery systems, self-contained emergency lighting, and advanced evacuation technologies.

Our mission is to safeguard lives by delivering high-performance, energy-efficient systems that meet the strictest international standards. Whether for commercial buildings, industrial facilities, healthcare institutions, or residential complexes, Exilux combines advanced engineering, durability, and user-friendly design to create lighting solutions that perform when it matters most.

Backed by teams of experts and a commitment to excellence, Exilux is your trusted partner for reliable emergency lighting you can count on in critical situations. Explore our solutions and discover how we illuminate safety with precision and innovation.

"Every Exilux product arrives ready to perform, giving you peace of mind and a faster, more efficient installation process."

Diverse sector experience

Our team has successfully delivered lighting solutions across a wide range of industries. In factories, rail, warehouses, car parks, museums, churches, airports, schools, universities, hospitals, retail units, and stadiums. We ensure compliance, functionality, and safety while enhancing the aesthetics of each space.

Bench testing for quality assurance

Before any product or system reaches your site, it undergoes comprehensive bench testing to ensure it meets the highest standards of performance and safety and that every component works exactly as it should.

Individual product testing: Each product is tested for functionality, durability, and regulatory compliance. This includes power supplies and luminaires.

How we work, from concept to completion

Professional advice

Our in-house experts offer personalised, on-site consultations. We listen carefully to your needs and draw upon decades of industry experience to provide bespoke solutions that cater to your unique requirements while adhering to the latest compliance standards.

Project management

From concept to completion, our regional managers ensure that via one main point of contact you gain access to key members of our team at each and every stage of your project. Our services include detailed design, product sourcing, proactive tender support, order and delivery management, pre-installation training, and aftercare support, ensuring a smooth and seamless experience.

Monitoring and testing

Our bespoke testing and monitoring systems routinely test emergency lighting both on-site and remotely. Identifying and reporting any defects, helping you identify the nature of any faults and detailing any necessary parts, ensuring you are able to keep your system compliant in the most efficient way.

Technical support

We deliver intelligent, technical solutions backed by comprehensive lighting calculations, design expertise, and precise specification recommendations to ensure the best outcome for your project.

Service and commissioning

Our team commissions your chosen systems to ensure control units are communicating with their designated luminaires and performing in accordance with the design intent. We also offer system training, software upgrades, and ongoing service and support to keep your systems running smoothly.

Specialist training

We provide industry-leading one-to-one training and group seminars, equipping you and your teams with the knowledge and skills to maintain your systems and products at their best.

NRG+

LPS

Low Power Safety Supply System (LPS) – Fully Compliant with BS EN 50171, BS EN 62485-2 and BS EN 62034.

Our Low Power Safety Supply System (LPS) delivers reliable backup power for emergency lighting systems, ensuring compliance with BS EN 50171, BS EN 62485-2, and BS EN 62034. Designed for uninterrupted operation during power outages, it safeguards building occupants by maintaining emergency escape lighting, exit signs, and essential safety equipment.



Why choose our LPS system?

- Guarantees compliance with EU/UK safety regulations
- Enhances occupant safety with fail-safe emergency power
- Reduces maintenance costs through automated testing and diagnostics
- Ensure safety power and meet legal requirements, high-reliability LPS system

Key features:

- *Seamless automatic switchover* – Transition to backup power upon mains failure
- *High-performance battery backup* – Long-life batteries providing 1-3 hours of emergency runtime (configurable to meet local regulations)
- *Smart monitoring and self-testing* – Continuous diagnostics for battery health, charge status, and system integrity
- Test facility with automated or manual release function and logbook for status and failure information
- *Energy-efficient operation* – Optimised power consumption without compromising safety
- *Compact and robust design* – Easy integration into electrical rooms, or dedicated fireproof enclosures.
- *Wide application range* – Suitable for commercial buildings, industrial sites, hospitals, tunnels, and public infrastructure
- Fully automatic function monitoring including individual luminaire and circuit fault detection without additional data line
- USB interface for updating
 - Updating the control unit software
 - Load/save unit configuration
 - Load/save the circuit configuration
 - Connection of a standard keyboard
- Management of up to 8 circuits (up to 160 luminaires – max. of 20 luminaires per circuit)

Full compliance – meets:

- BS EN 50171 (Central Power Supply Systems)
- BS EN 62485-2 (Safety Requirements for Stationary Battery Installations)
- BS EN 62034 (Automatic Testing for Battery-Powered Emergency Lighting)

LPS with *NRG+*

Luminaires and NRG+ ULM Addressable Module for individual fitting control and programming

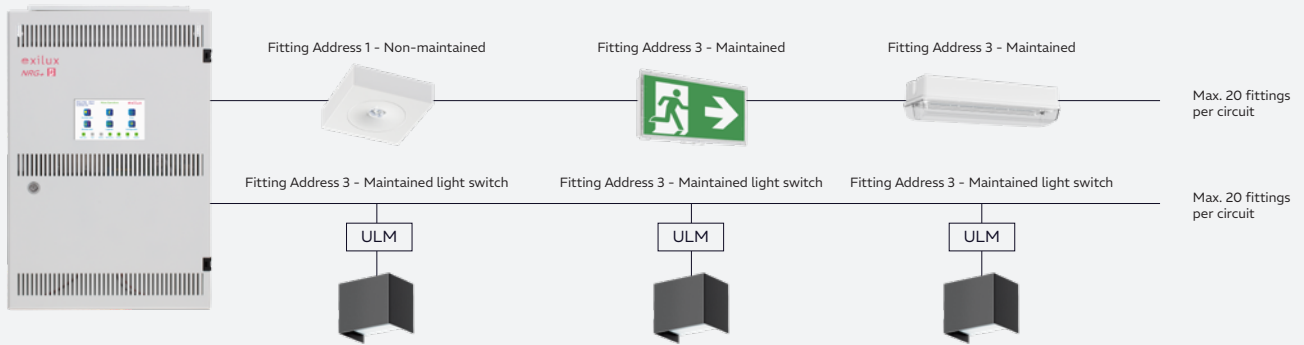

LPS with *NRG*

Luminaires and general lighting for circuit monitoring

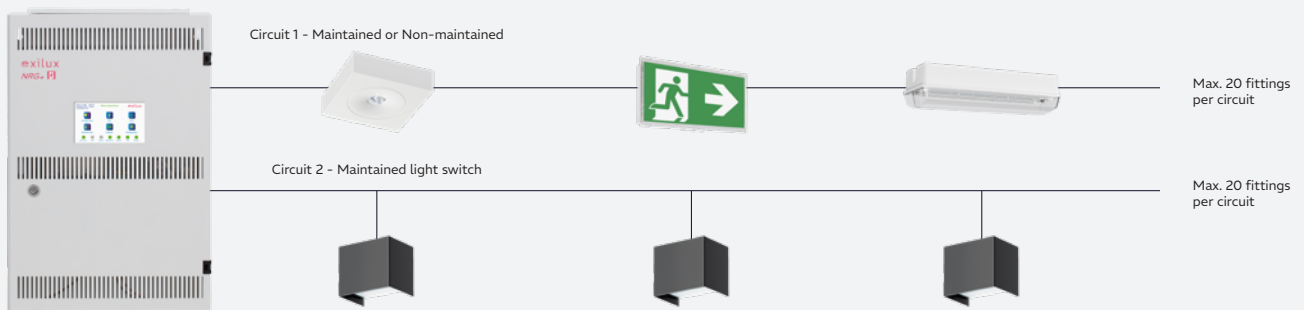

NRG+ LPS typical connection diagram

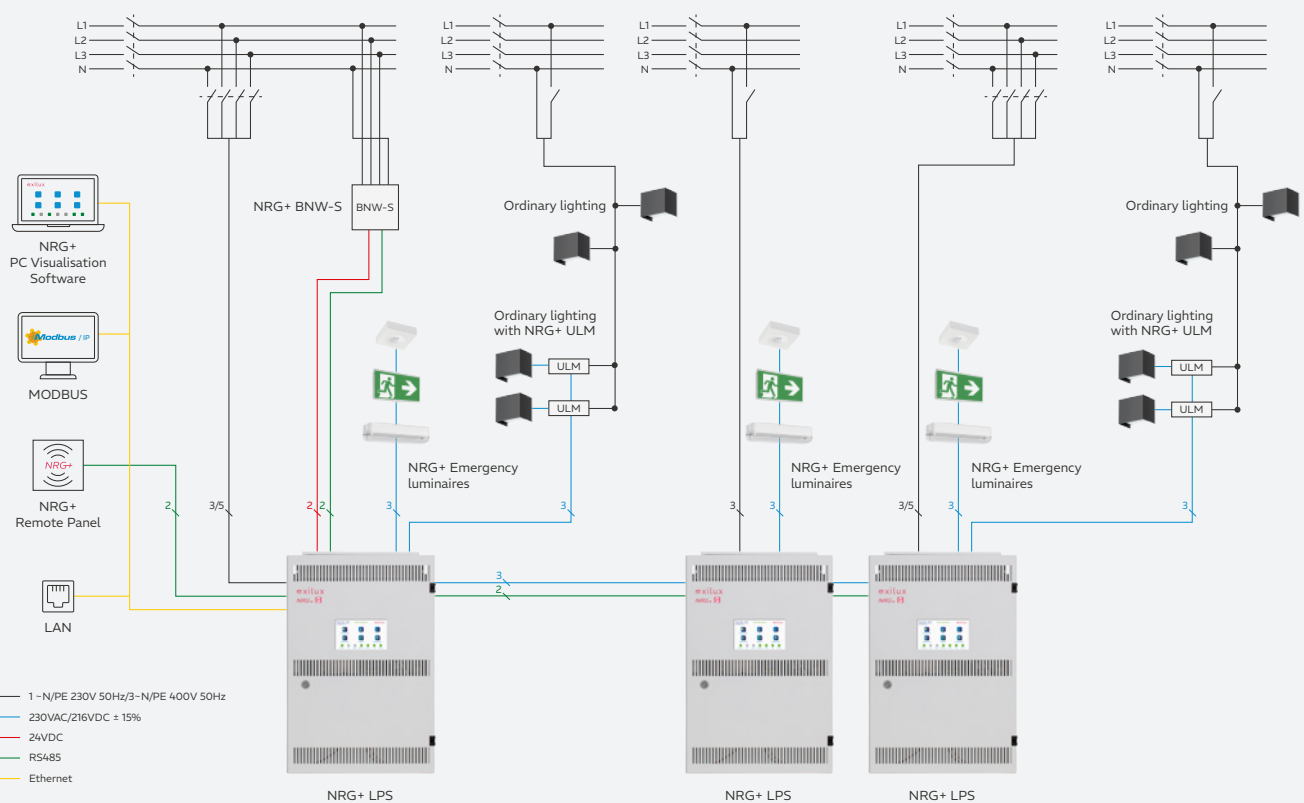

NRG+

LPS 230

Low Power System (LPS) for emergency lighting.

230 V AC/DC outgoing circuits with integrated monitoring and maintained and non-maintained functions.

User-friendly 7" Touchscreen-Display, integrated Modbus interface.



Features

- Each circuit for max. 20 luminaires
- Single luminaire monitoring
- 3 inputs potential-free -3 inputs with potential 230 V AC
– 2 inputs with potential 24-230 V AC/DC
- 8 relay outputs freely programmable 230 V / 2 A
- USB interface for keyboard, mouse or USB memory stick
- TCP/IP interface for networking or visualisation
- Easy commissioning of the system via menu navigation
- Switching of individual luminaires or groups of luminaires via switching inputs
- Simple but powerful automatic luminaire search
- Menu for recognising double addresses
- Automatic test equipment and integrated test logbook
- Supervision software up to 253 systems for visualisation and control
- High efficiency charging modules with temperature compensation

Technical specifications

Nominal input voltage	1-N/PE 230 V 50 Hz / 3-N/PE 400 V 50 Hz
Nominal output voltage	230 VAC/216 VDC ±15 %
Outgoing circuits	0.87 A 200 W 4 or 8 circuits
Battery	AGM-VRLA 18 x 9 Ah - 10 YEARS expected lifespan
Autonomy and power according EN 50171	1 h max. 870 W - 3 h max. 380 W
System standby power	34 W
Charging time	12 h
Colour and material	RAL 9016 - galvanised and painted metal sheet
Interface	TCP / IP - MODBUS - USB
Insulation class	I
Operating temperature	0 °C to +40 °C, Batteries 20 °C to +25 °C
Mounting	Wall mounting
Cable entry	Above
Weight	Approx. 72.5 kg
Protection rating	IP20
Dimensions (H x W x D)	800 x 600 x 180 mm

NRG+

LPS 24-230

Low Power System (LPS) for emergency lighting.

230 V AC/DC outgoing circuits with integrated monitoring and maintained and non-maintained functions.

User-friendly 7" Touchscreen Display, integrated Modbus interface.

Designed according to BS EN 50171 and BS EN 50272.



Features

- Each circuit for max. 20 luminaires
- Single luminaire monitoring
- 3 inputs potential-free -3 inputs with potential 230 V AC
– 2 inputs with potential 24-230 V AC/DC
- 8 relay outputs freely programmable 230 V / 2 A
- USB interface for keyboard, mouse or USB memory stick
- TCP/IP interface for networking or visualisation
- Easy commissioning of the system via menu navigation
- Switching of individual luminaires or groups of luminaires via switching inputs
- Simple but powerful automatic luminaire search
- Menu for recognising double addresses
- Automatic test equipment and integrated test logbook
- Supervision software up to 253 systems for visualisation and control
- High efficiency charging modules with temperature compensation

Technical specifications

Nominal input voltage	1-N/PE 230 V 50 Hz / 3-N/PE 400 V 50 Hz
Nominal output voltage	230 VAC / 230 VDC ±5 %
Outgoing circuits	0.87 A 200 W 4 or 8 circuits
Battery	AGM-VRLA from 13 to 52 Ah - 10 YEARS expected lifespan
Autonomy and power according EN 50171	1 h from 128 to 250 W - 3 h max. 46 to 230 W
System standby power	30.5 W
Charging time	12 h
Colour and material	RAL 9016 - galvanised and painted metal sheet
Interface	TCP / IP - MODBUS - USB
Insulation class	I
Operating temperature	0 °C to +40 °C, Batteries 20 °C to +25 °C
Mounting	Wall mounting
Cable entry	Above
Weight	Approx. 18.6 to 41.2 kg
Protection rating	IP20
Dimensions (H x W x D)	680 x 455 x 180 mm

NRG+

LPS 24-230 Li

Low Power System (LPS) for emergency lighting.

230 V AC/DC outgoing circuits with integrated monitoring and maintained and non-maintained functions.

User-friendly 7" Touchscreen-Display, integrated Modbus interface.

Features

- Each circuit for max. 20 luminaires
- Single luminaire monitoring
- 3 inputs potential-free -3 inputs with potential 230 V AC
– 2 inputs with potential 24-230 V AC/DC
- 8 relay outputs freely programmable 230 V / 2 A
- USB interface for keyboard, mouse or USB memory stick
- TCP/IP interface for networking or visualisation
- Easy commissioning of the system via menu navigation
- Switching of individual luminaires or groups of luminaires via switching inputs
- Simple but powerful automatic luminaire search
- Menu for recognising double addresses
- Automatic test equipment and integrated test logbook
- Supervision software up to 253 systems for visualisation and control
- High efficiency charging modules with temperature compensation

Technical specifications

Nominal input voltage	1-N/PE 230 V 50 Hz / 3-N/PE 400 V 50 Hz
Nominal output voltage	230 VAC / 230 VDC ±5 %
Outgoing circuits	0.87 A 200 W 4 or 8 circuits
Battery	Lithium form 17 to 51 Ah - 10 YEARS expected lifespan
Autonomy and power according EN 50171	1 h from 200 to 250 W - 3 h from 90 to 250 W
System standby power	30.5 W
Charging time	12 h
Colour and material	RAL 9016 - galvanised and painted metal sheet
Interface	TCP / IP - MODBUS - USB
Insulation class	I
Operating temperature	-10 °C to +55 °C
Mounting	Wall mounting
Cable entry	Above
Weight	Approx. from 18.6 to 41.2 kg
Protection rating	IP20
Dimensions (H x W x D)	680 x 455 x 180 mm

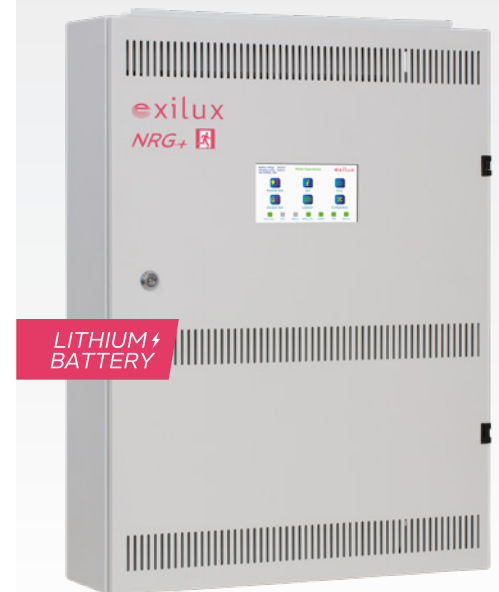

NRG+

LPS 24-230 Li IP66

Low Power System (LPS) for emergency lighting.

230 V AC/DC outgoing circuits with integrated monitoring and maintained and non-maintained functions.

User-friendly 7" Touchscreen-Display, integrated Modbus interface.



Features

- Each circuit for max. 20 luminaires
- Single luminaire monitoring
- 3 inputs potential-free -3 inputs with potential 230 V AC
– 2 inputs with potential 24-230 V AC/DC
- 8 relay outputs freely programmable 230 V / 2 A
- USB interface for keyboard, mouse or USB memory stick
- TCP/IP interface for networking or visualisation
- Easy commissioning of the system via menu navigation
- Switching of individual luminaires or groups of luminaires via switching inputs
- Simple but powerful automatic luminaire search
- Menu for recognising double addresses
- Automatic test equipment and integrated test logbook
- Supervision software up to 253 systems for visualisation and control
- High efficiency charging modules with temperature compensation

Technical specifications

Nominal input voltage	1-N/PE 230 V 50 Hz / 3-N/PE 400 V 50 Hz
Nominal output voltage	230 VAC / 230 VDC ±5 %
Outgoing circuits	0.87 A 200 W 4 or 8 circuits
Battery	Lithium form 17 to 51 Ah - 10 YEARS expected lifespan
Autonomy and power according EN 50171	1 h from 200 to 250 W - 3 h from 90 to 250 W
System standby power	30.5 W
Charging time	12 h
Colour and material	RAL 7035 - galvanised and painted metal sheet
Interface	TCP / IP - MODBUS - USB
Insulation class	I
Operating temperature	-10 °C to +55 °C
Mounting	Wall mounting
Cable entry	Above
Weight	Approx. from 15.4 to 24.2 kg
Protection rating	IP66
Dimensions (H x W x D)	600 x 600 x 210 mm

NRG+

CPS

Central Power Supply (CPS) System Fully Compliant with BS EN 50171, BS EN 62485-2 and BS EN 62034.

Our Central Power Supply (CPS) System is a fully integrated backup power solution that ensures safety power for emergency lighting, exit signs, and critical safety equipment. Designed to meet the strictest European standards—EN 50171, BS EN 62485-2, and BS EN 62034, it guarantees safe building evacuation during power failures by automatically supplying backup power to connected safety systems.

Why choose our CPS system?

- Guarantees compliance with EU/UK safety regulations
- Enhances occupant safety with fail-safe emergency power
- Reduces maintenance costs through automated testing and diagnostics
- Ensure safety power and meet legal requirements, high-reliability CPS system

Key features:

- *Seamless automatic switchover* – Transition to backup power upon mains failure
- *High-performance battery backup* – Long-life batteries providing 1-3 hours of emergency runtime (configurable to meet local regulations)
- *Smart monitoring and self-testing* – Continuous diagnostics for battery health, charge status, and system integrity
- Test facility with automated or manual release function and logbook for status and failure information
- *Energy-efficient operation* – Optimised power consumption without compromising safety
- *Robust design* – Easy integration into electrical rooms, or dedicated fireproof enclosures
- *Wide application range* – Suitable for commercial buildings, industrial sites, hospitals, tunnels, and public infrastructure
- Fully automatic function monitoring including individual luminaire and circuit fault detection without additional data line
- USB interface for updating
 - Updating the control unit software
 - Load/save unit configuration
 - Load/save the circuit configuration
 - Connection of a standard keyboard
- Management of up to 72 circuits (up to 1440 luminaires – max. of 20 luminaires per circuit)
- In a project that includes SUBs, you can manage up to 256 circuits (up to 5120 luminaires, with a maximum of 20 luminaires per circuit) on the same unit

Full compliance – meets:

- BS EN 50171 (Central Power Supply Systems)
- BS EN 62485-2 (Safety Requirements for Stationary Battery Installations)
- BS EN 62034 (Automatic Testing for Battery-Powered Emergency Lighting)



CPS with *NRG+*

Luminaires and NRG+ ULM Addressable Module for individual fitting control and programming

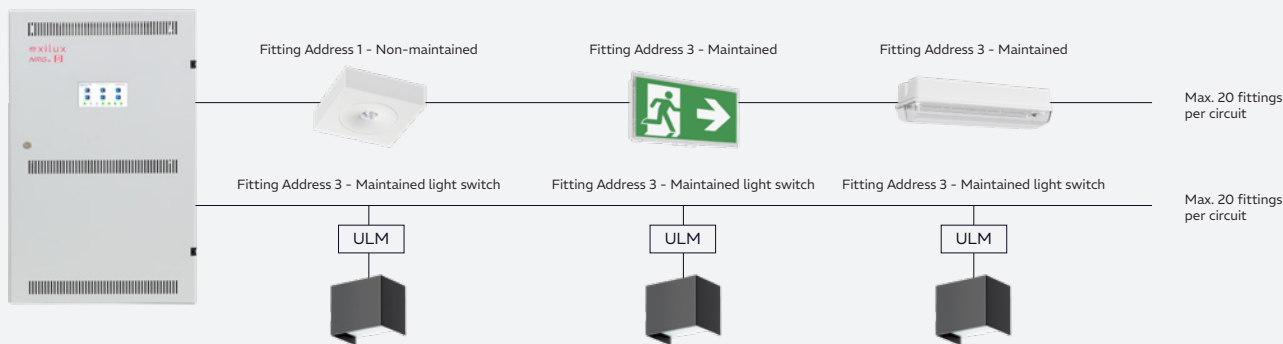

CPS with *NRG*

Luminaires and general lighting for circuit monitoring

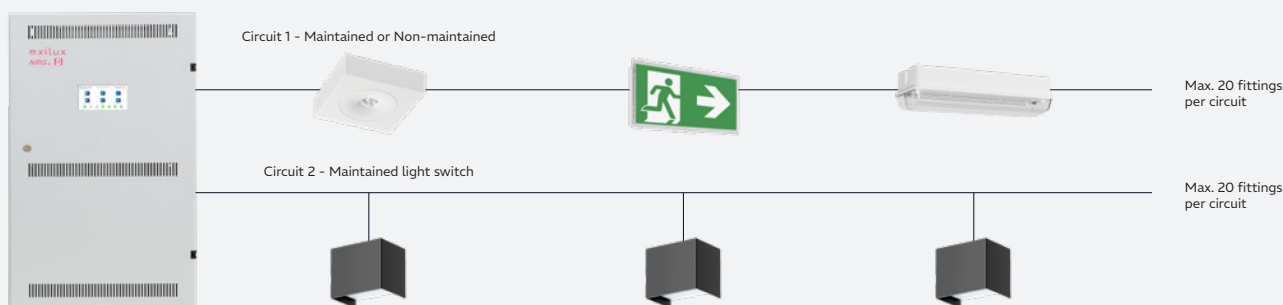

NRG+ CPS typical connection diagram

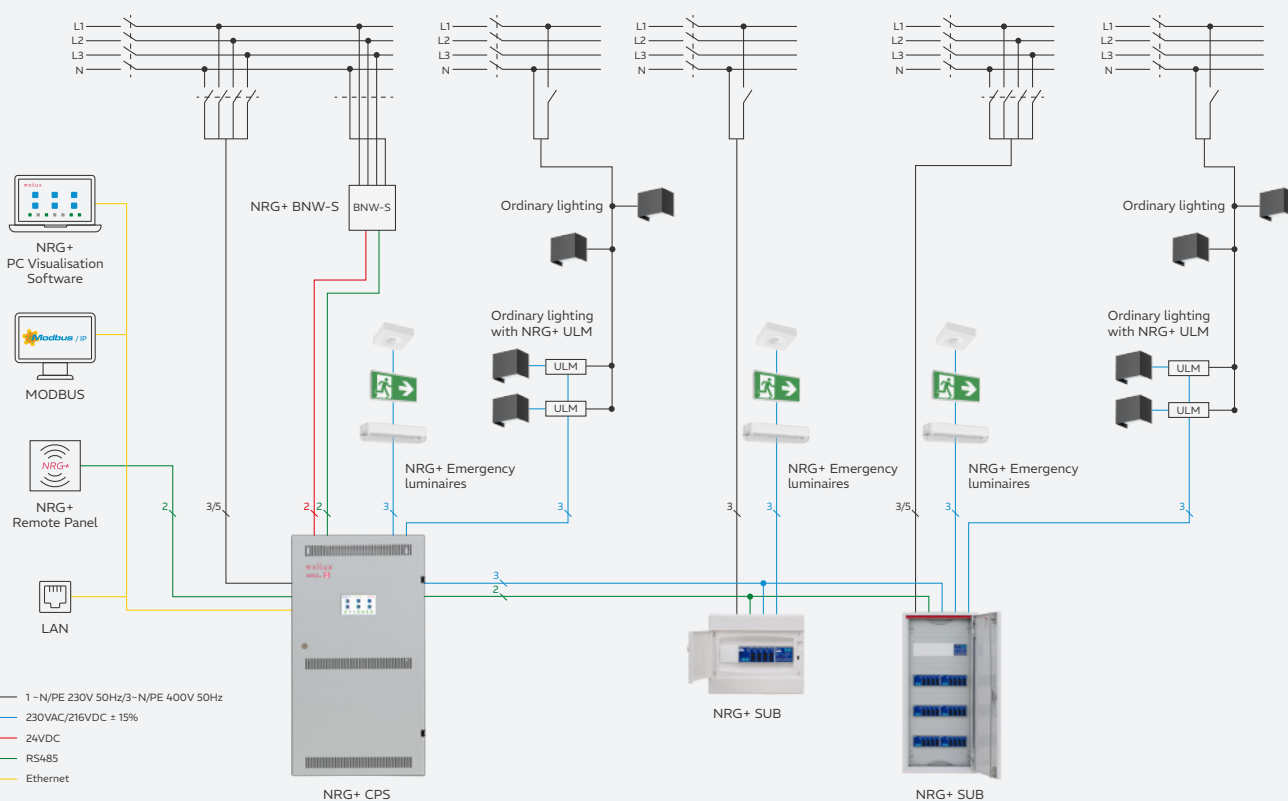

NRG+

CPS S28

Central Power System (CPS) for emergency lighting.

230 V AC/DC outgoing circuits with integrated monitoring and maintained and non-maintained functions.

User-friendly 7" Touchscreen-Display, integrated Modbus interface.

Designed according to BS EN 50171, BS EN 62485-2, BS EN 62034.



Features

- Each circuit for max. 20 luminaires
- Single luminaire monitoring
- 8 switching inputs freely programmable (potential free)
- 8 relay outputs freely programmable 230 V / 2 A
- Bus connection for substations or external modules
- USB interface for keyboard, mouse or USB memory stick
- TCP/IP interface for networking or visualisation
- Easy commissioning of the system via menu navigation
- Switching of individual luminaires or groups of luminaires via switching inputs
- Simple but powerful automatic luminaire search
- Menu for recognising double addresses
- Automatic test equipment and integrated test logbook
- Supervision software up to 253 systems for visualisation and control
- IU characteristic charger with separate charge controller and control of redundant charging modules
- High efficiency charging modules with temperature compensation
- Up to 5 circuits for substations

Technical specifications

Nominal input voltage	1-N/PE 230 V 50 Hz / 3-N/PE 400 V 50 Hz
Nominal output voltage	230 VAC / 216 VDC ±15 %
Outgoing circuits	2 x 6 A 1380 W or 4 x 3 A 690 W (max. up to 7 output modules)
Battery	AGM-VRLA from 7.2 to 28 Ah - 10 YEARS expected lifespan
Autonomy and power according EN 50171	1 h from 753.41 to 2885.76 W - 3 h from 297.22 to 1152.58 W
System standby power	1 h from 103.6 to 110.4 W / 3 h 103.6 W
Charging time	12 h
Colour and material	RAL 7035 - galvanised and painted metal sheet
Interface	TCP / IP - MODBUS - USB
Insulation class	I
Operating temperature	0 °C to +40 °C, Batteries 20 °C to +25 °C
Mounting	Wall mounting
Cable entry	Above
Weight	Approx. from 100 to 210 kg
Protection rating	IP20
Dimensions (H x W x D)	1100 x 600 x 422 mm

NRG+

CPS B72

Central Power System (CPS) for emergency lighting.

230 V AC/DC outgoing circuits with integrated monitoring and maintained and non-maintained functions.

User-friendly 7" Touchscreen-Display, integrated Modbus interface.

Designed according to BS EN 50171, BS EN 62485-2, BS EN 62034.



Features

- Each circuit for max. 20 luminaires
- Single luminaire monitoring
- 8 switching inputs freely programmable (potential free)
- 8 relay outputs freely programmable 230 V / 2 A
- Bus connection for substations or external modules
- USB interface for keyboard, mouse or USB memory stick
- TCP/IP interface for networking or visualisation
- Easy commissioning of the system via menu navigation
- Switching of individual luminaires or groups of luminaires via switching inputs
- Simple but powerful automatic luminaire search
- Menu for recognising double addresses
- Automatic test equipment and integrated test logbook
- Supervision software up to 253 systems for visualisation and control
- IU characteristic charger with separate charge controller and control of redundant charging modules
- High efficiency charging modules with temperature compensation
- Up to 6 circuits for substations

Technical specifications

Nominal input voltage	1-N/PE 230 V 50 Hz / 3-N/PE 400 V 50 Hz
Nominal output voltage	230 VAC / 216 VDC ±15 %
Outgoing circuits	2 x 6 A 1380 W or 4 x 3 A 690 W (max. up to 18 output modules)
Battery	AGM-VRLA from 7.2 to 250 Ah - 10 YEARS expected lifespan
Autonomy and power according EN 50171	1 h from 753.41 to 24537.60 W - 3 h from 297.22 to 11024.64 W
System standby power	1 h from 140.3 to 321.3 W / 3 h 140.3 to 321.3 W
Charging time	12 h
Colour and material	RAL 7035 - galvanised and painted metal sheet
Interface	TCP / IP - MODBUS - USB
Insulation class	I
Operating temperature	0 °C to +40 °C, Batteries 20 °C to +25 °C
Mounting	Floor standing mounting
Cable entry	Above
Weight	Approx. from 200 to 1850 kg
Protection rating	IP20
Dimensions (H x W x D)	CPS 1800 x 800 x 600 mm Battery cabinet from 120 to 250 Ah - 1800 x 800 x 600 mm

NRG+

Lithium CPS

Where absolute reliability is critical, the NRG+ CPS Li Central Power Systems redefines emergency power system with cutting-edge lithium technology, with 10-year guaranteed batteries. Engineered for mission-critical applications, this advanced system delivers instant response, seamless energy backup, and intelligent power management—ensuring uninterrupted operation when it matters most.

Fully compliant with the highest industry standards, including BS EN 50171 (Central Power Systems), BS EN 62485-2 (safety requirements for secondary lithium batteries), and BS EN 62034 (automatic test systems for emergency lighting), the NRG+ CPS Li guarantees safety, performance, and long-term reliability. Its rugged design minimises maintenance while maximising efficiency, making it the ideal solution for:

- Industrial and manufacturing plants
- Healthcare facilities and data centers
- Public infrastructure and transportation hubs
- High-risk environments requiring fail-safe power
- With real-time monitoring, remote diagnostics, and scalable configurations,

NRG+ CPS Li isn't just an emergency Central Power Systems it's a future-proof investment in resilience. Engineered for emergencies. Built to last. Developed for compliance.



Lithium battery advantages

- Absolutely gas-free and requires no ventilation
- Longer lifetime: over 15 years
- 2/3 less weight and space required
- Intelligent safety monitoring BMS
- Allows 90 % removable energy in 1 and 3 hours
- Ideal for installations with extended temperature ranges
- More sustainable and efficient overall

Intelligent safety technology BMS battery-management-system

Single Cell Monitoring: Each cell block is monitored at 100 %. In an emergency, the cell block is switched off and an error message is displayed on the unit.

- Monitoring
- Temperature
- Voltage
- Deep discharge protection
- Overcharge protection
- Short-circuit



CPS Lithium controller UI

No ventilation and no air conditioning is required

During the charging process of a lead-acid battery, hydrogen and oxygen are released into the atmosphere through electrolysis, forming oxyhydrogen. The lower explosion limit of this hydrogen concentration is approximately 4 %. The resulting risks and specifications for venting are prescribed and mandatory in the BS EN 62485-2 standard.

Lithium advantage:

- No explosive hydrogen mixture or other hazardous substances are produced
- There is no need for ventilation or air conditioning

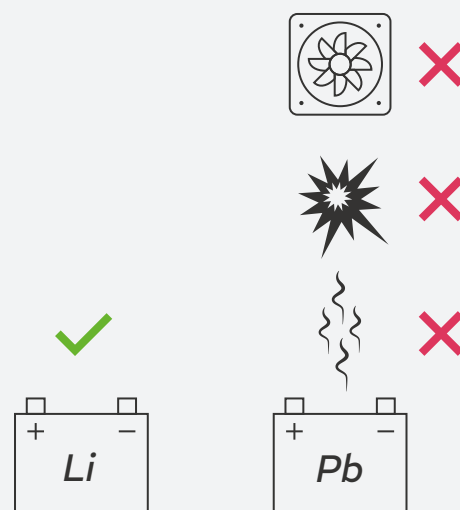

Lithium battery v traditional lead battery

SAVING ON INSTALLATION AND OPERATING COSTS, AND AIR CONDITIONING

NRG+

CPS M60 Li

Central Power System (CPS) for emergency lighting.

230V AC/DC outgoing circuits with integrated monitoring and maintained and non-maintained functions.

User-friendly 7" Touchscreen-Display, integrated Modbus interface. Designed according to BS EN 50171, BS EN 62485-2, BS EN 62034.

Features

- Each circuit for max. 20 luminaires
- Single luminaire monitoring
- 8 switching inputs freely programmable (potential free)
- 8 relay outputs freely programmable 230 V/2 A
- Bus connection for substations or external modules
- USB interface for keyboard, mouse or USB memory stick
- TCP/IP interface for networking or visualisation
- Easy commissioning of the system via menu navigation
- Switching of individual luminaires or groups of luminaires via switching inputs
- Simple but powerful automatic luminaire search
- Menu for recognising double addresses
- Automatic test equipment and integrated test logbook
- Supervision software up to 253 systems for visualisation and control
- Charger with an external control unit with intelligent safety technology, BMS (Battery Management System)
- High efficiency charging modules with temperature compensation
- Up to 6 circuits for substations

Technical specifications

Nominal input voltage	1-N/PE 230 V 50 Hz / 3-N/PE 400 V 50 Hz
Nominal output voltage	230 VAC / 216 VDC ±15 %
Outgoing circuits	2 x 6 A 1380 W or 4 x 3 A 690 W (max. up to 15 output modules)
Battery	NMC 5 x 44 V 37 Ah - 10 YEARS WARRANTY
Autonomy and power according EN 50171	1 h max. 5861 W - 3 h max. 1954 W
System standby power	1 h 152.3 W / 3 h 152.3 W
Charging time	12 h
Colour and material	RAL 7035 - galvanised and painted metal sheet
Interface	TCP / IP - MODBUS - USB
Insulation class	I
Operating temperature	-10 °C to +50 °C, Batteries -10 °C to +50 °C
Mounting	Wall mounting
Cable entry	Above
Weight	Approx. 130 kg
Protection rating	IP20
Dimensions (H x W x D)	1200 x 800 x 420 mm



NRG+

CPS B72 Li

Central Power System (CPS) for emergency lighting.

230V AC/DC outgoing circuits with integrated monitoring and maintained and non-maintained functions.

User-friendly 7" Touchscreen-Display, integrated Modbus interface. Designed according to BS EN 50171, BS EN 62485-2, BS EN 62034.

LITHIUM
BATTERY



Features

- Each circuit for max. 20 luminaires
- Single luminaire monitoring
- 8 switching inputs freely programmable (potential free)
- 8 relay outputs freely programmable 230 V/2 A
- Bus connection for substations or external modules
- USB interface for keyboard, mouse or USB memory stick
- TCP/IP interface for networking or visualisation
- Easy commissioning of the system via menu navigation
- Switching of individual luminaires or groups of luminaires via switching inputs
- Simple but powerful automatic luminaire search
- Menu for recognising double addresses
- Automatic test equipment and integrated test logbook
- Supervision software up to 253 systems for visualisation and control
- Charger with an external control unit with intelligent safety technology, BMS (Battery Management System)
- High efficiency charging modules with temperature compensation
- Up to 6 circuits for substations

Technical specifications

Nominal input voltage	1-N/PE 230 V 50 Hz / 3-N/PE 400 V 50 Hz
Nominal output voltage	230 VAC / 216 VDC ±15 %
Outgoing circuits	2 x 6 A 1380 W or 4 x 3 A 690 W (max. up to 18 output modules)
Battery	LFP 9 x 25.6 V 105 Ah - 10 YEARS WARRANTY
Autonomy and power according EN 50171	1 h max. 16632 W - 3 h max. 5544 W
System standby power	1 h 218.3 W / 3 h 218.3 W
Charging time	12 h
Colour and material	RAL 7035 - galvanised and painted metal sheet
Interface	TCP / IP - MODBUS - USB
Insulation class	I
Operating temperature	0 °C to +50 °C, Batteries 0 °C to +50 °C
Mounting	Floor standing mounting
Cable entry	Above
Weight	Approx. 200 kg
Protection rating	IP20
Dimensions (H x W x D)	1800 x 800 x 600 mm

NRG+

SUB S

NRG+ Sub for sub-distribution areas and system extensions.

230 V AC/DC outgoing circuits with integrated monitoring and maintained and non-maintained functions.

Designed according to BS EN 50171, BS EN 62034.

Technical specifications

Nominal input voltage	1-N/PE 230 V 50 Hz
Nominal output voltage	230 VAC / 216 VDC ±15 %
Outgoing circuits	4 x 3 A 690 W from (max. up to 16 circuit)
Colour and material	RAL 9003 - ABS GWT 650 °C
Insulation class	II
Operating temperature	0 °C to +40 °C
Mounting	Wall mounting
Cable entry	Above
Weight	Approx. from 2 to 5 kg
Protection rating	IP40
Dimensions (H x W x D)	from 236 x 287 x 112 mm to 482 x 287 x 112 mm



NRG+

SUB B

NRG+ Sub for sub-distribution areas and system extensions.

230 V AC/DC outgoing circuits with integrated monitoring and maintained and non-maintained functions.

Designed according to BS EN 50171, BS EN 62034.

Technical specifications

Nominal input voltage	1-N/PE 230 V 50 Hz
Nominal output voltage	230 VAC / 216 VDC ±15 %
Outgoing circuits	4 x 3 A 690 W from (max. up to 48 circuit)
Colour and material	RAL 9016 - galvanised and painted metal sheet
Insulation class	I
Operating temperature	0 °C to +40 °C
Mounting	Wall mounting
Cable entry	Above
Weight	Approx. from 15 to 29 kg
Protection rating	IP40
Protection rating	IP40
Dimensions (H x W x D)	from 236 x 287 x 112 mm to 482 x 287 x 112 mm



NRG+

IOe24

Light switch query module, each of the 8 digital input can be configured as a current loop function or to switch groups or individual luminaires on and off.

The IOe24 also has 3 digital outputs with potential-free changeover contacts.

The two status LEDs provide information about the operating status.

During normal operation of the system, the green LED flashes each time the module requests a BUS signal (approx. every 100 ms).

The red LED lights up when the module itself is in an error state or when the BUS is inactive.

The two rotary switches are used to set a unique address for each IOe24 in the system (addresses 1 - 56).



Technical specifications

Nominal input voltage	24 VDC	Insulation class	III
Light switch input	8 x potential free contacts	Operating temperature	-40 °C to +85 °C
Changeover contacts	3 x 6 A 250 V	Mounting	DIN rail
Max. length RS 485 BUS	1000 m	Weight	Approx. 0.17 kg
RS 485 connection cable	4 x 2 x 0.8 mm ²	Protection rating	IP20
Max. consumption	1.45 W	Dimensions (H x W x D)	90 x 52.5 x 71 mm
Colour and material	RAL 7035 - PC		

Wiring diagram

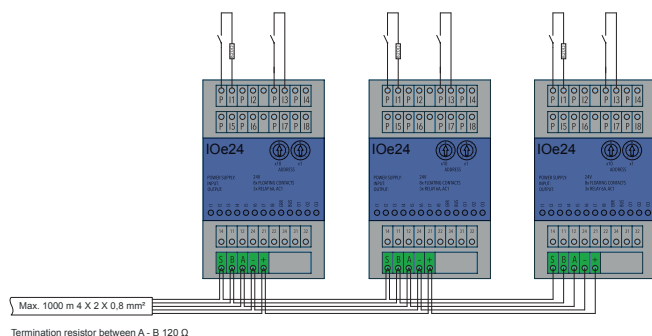

Additional information

11-8/N1-8	8 x digital input configurable as: IN to P closed = 1 IN to P closed = 0 (inverted) IN to P with 82 R as current loop
OUT 1-3	3 x digital output with potential-free change over contact 11 - 12: normally closed (nc) 11 - 14: normally open contact (no)
LED status inputs	Normal function: P - I bridged = LED on P - I open = LED off Current loop function: P - I bridged with R 820 R = LED on P - I short-circuited = LED flashes quickly P - I open = LED flashes
LED status outputs „01 - 03“	Indicator lights up on active output
LED status „Error“	Off - BUS error-free On - BUS has errors
LED status „Bus“	Flashes during BUS activity

NRG+

IOe230-S

Light switch query module, each of the 8 inputs can monitor 230 V mains voltage and can be programmed to switch groups or individual luminaires on and off.

The IOe230-S also has 3 digital outputs with potential-free changeover contacts.

The outputs can be freely configured in the CPS and LPS system.

If the voltage falls below the lower threshold value or it is interrupted, the corresponding green LED on the front of the module goes out.

The two status LEDs provide information about the operating status.

During normal operation of the system, the green LED flashes each time the module requests a BUS signal (approx. every 100 ms).

The red LED lights up when the module itself is in an error state or when the BUS is inactive.

The two rotary switches are used to set a unique address for each IOe230-S in the system (addresses 1 - 56).



Technical specifications

Nominal input voltage	24 VDC	Insulation class	II
Light switch input	8 x 230 V 50 Hz	Operating temperature	-40 °C to +85 °C
Changeover contacts	3 x 6 A 250 V	Mounting	DIN rail
Max. length RS 485 BUS	1000 m	Weight	Approx. 0.17 kg
RS 485 connection cable	4 x 2 x 0.8 mm ²	Protection rating	IP20
Max. consumption	1.45 W	Dimensions (H x W x D)	90 x 52.5 x 71 mm
Colour and material	RAL 7035 - PC		

Wiring diagram

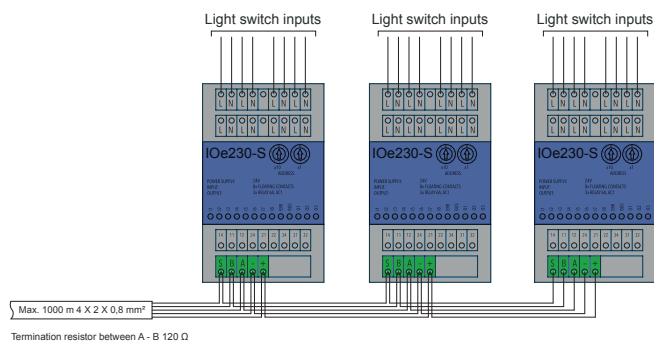

Additional information

11-8/N1-8	8 x input 230 V 50 Hz
OUT 1-3	3 x digital output with potential-free change over contact 11 - 12: normally closed (nc) 11 - 14: normally open contact (no)
LED status inputs	> 185 V = LED on
LED status outputs „01 - 03“	Indicator lights up on active output
LED status „Error“	Off - BUS error-free On - BUS has errors
LED status „Bus“	Flashes during BUS activity

NRG+

BNW-S

Single-phase and three-phase addressable mains monitoring module.

The two status LEDs provide information about the operating status.

During normal operation of the system, the green LED flashes each time the module requests a BUS signal (approx. every 100 ms).

The red LED lights up when the module itself is in an error state or when the BUS is inactive.

The two rotary switches are used to set a unique address for each BNW-S in the system (addresses 1 - 56).



Technical specifications

Nominal input voltage	24 VDC
Mains voltage monitoring	1-N 230 V 50 Hz or 3-N 230/400 V 50 Hz
Max. length RS 485 BUS	1000 m
RS 485 connection cable	4 x 2 x 0.8 mm ²
Max. consumption	1 W
Colour and material	RAL 7035 - PC
Insulation class	II
Operating temperature	-40 °C to +85 °C
Mounting	DIN rail
Weight	Approx. 0.075 kg
Protection rating	IP20
Dimensions (H x W x D)	90 x 35 x 65 mm

Wiring diagram

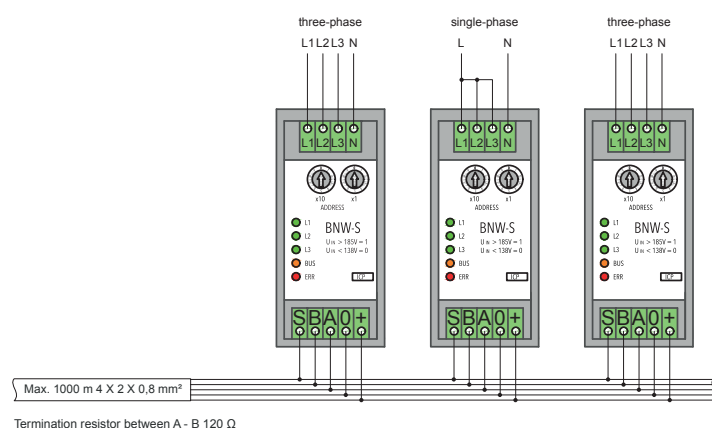

NRG+

BNW-5i-S

Three-phase addressable mains monitoring module with 5 additional inputs for DB monitoring.

The two status LEDs provide information about the operating status.

During normal operation of the system, the green LED flashes each time the module requests a BUS signal (approx. every 100 ms).

The red LED lights up when the module itself is in an error state or when the BUS is inactive.

The two rotary switches are used to set a unique address for each BNW-5i-S in the system (addresses 1 - 56).



Technical specifications

Nominal input voltage	24 VDC
Mains voltage monitoring	1-N 230 V 50 Hz or 3-N 230/400 V 50Hz
Max. length RS 485 BUS	1000 m
RS 485 connection cable	4 x 2 x 0.8 mm ²
Max. consumption	1 W
Colour and material	RAL 7035 - PC
Insulation class	II
Operating temperature	-40 °C to +85 °C
Mounting	DIN rail
Weight	Approx. 0.105 kg
Protection rating	IP20
Dimensions (HxWxD)	90 x 87 x 65 mm

Wiring diagram

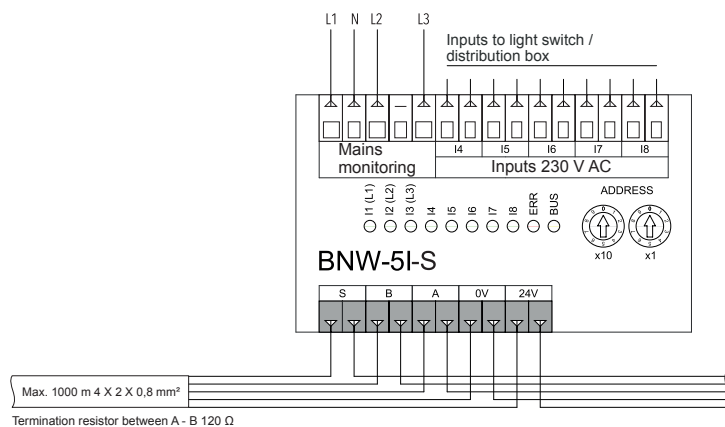

NRG+

ULM addressable module

Addressable monitoring module suitable for use with DALI and regular electronic ballasts or LED drivers.

Each outgoing circuit of the LPS or CPS can handle a maximum of 20 ULM modules.

The ULM module can be maintained and non-maintained mode for freely programmable mixed operation of the switching modes per luminaire on one circuit.

Universal monitoring module for loads from 2.5 to 250 W.

Designed according to BS EN 60598-2-22.

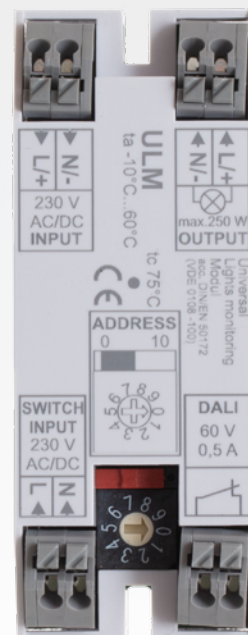

Technical specifications

Nominal input voltage	230 VAC / 216 VDC ±15 %
Switch input	230 VAC
Colour and material	RAL 9003 - PC
Insulation class	II
Operating temperature	-10 °C to +50 °C
Mounting	Inside mounting
Weight	Approx. 0.065 kg
Protection rating	IP20
Dimensions (H x W x D)	78 x 30 x 20 mm
Max. connectable load and max. inrush	250 W - 125 A 200 µs

Wiring diagram

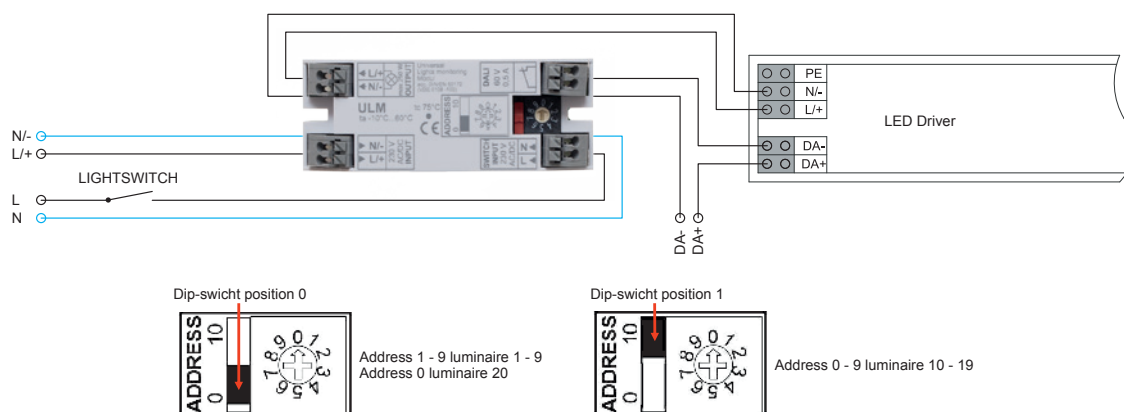

NRG+

PC visualisation software

The NRG+ PC Visualisation Software is a control and monitoring system designed for emergency safety lights and exit signs.

It can connect up to 253 LPS and CPS systems.

It carries out automatic function and duration tests, and records the results in a logbook. This ensures building managers comply with regulations, eliminating the hassle and cost of manually testing each luminaire.

Features

- Remote control of the systems via VNC connection
- Display of system status, error messages and all relevant operating data
- Programming of the systems
- Automatic programming and installation
- Optional: send emails in the event of faults
- Optional: acoustic message in case of faults
- Background operation notification (notify).
- Connection via LAN or WIFI
- Networking via existing LAN network or simple networking via switch
- Easy installation through automatic scan of all connected devices
- Direct access to any device
- High security - data exchange only via password protected port (SSH)
- List can be sorted by any field

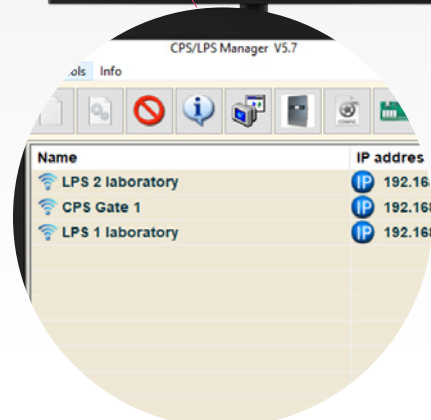
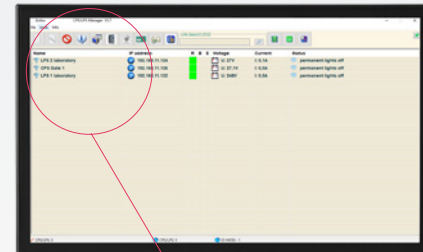

Wiring diagram

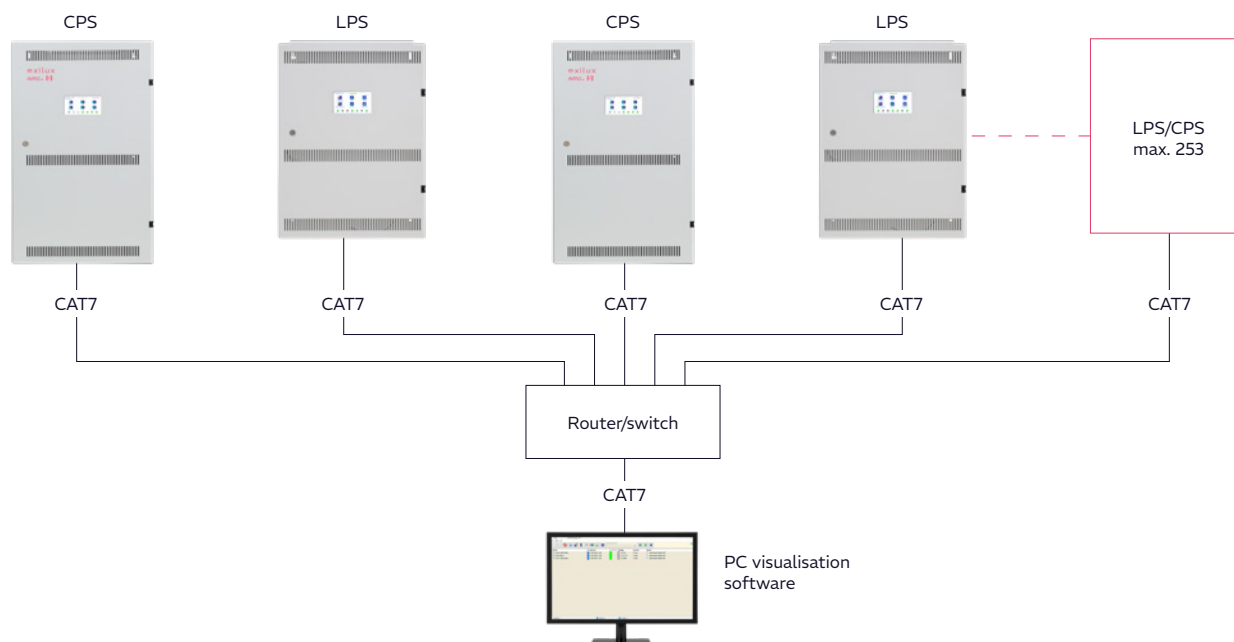

NRG+

Battery monitoring

Battery monitoring tracks the performance and condition of each battery block in real time.

It provides comprehensive supervision of voltage, charging current and temperature.

This monitoring helps to ensure that the battery performs and lasts as well as possible.

Features

- Periodic monitoring of battery block voltages
- Error message in case of battery block voltage deviation
- Manually reset the error message
- Recording of battery block voltages in endurance tests with an interval of 5 minutes
- Battery temperature monitoring – Two versions for 18 and 36 batteries are available, CLA15006 18 x battery block, CLA15007 36 x battery block

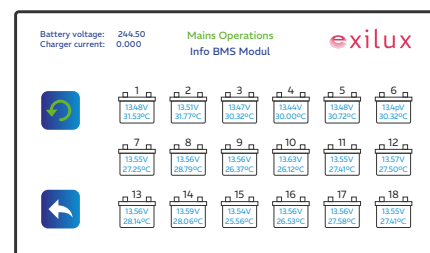
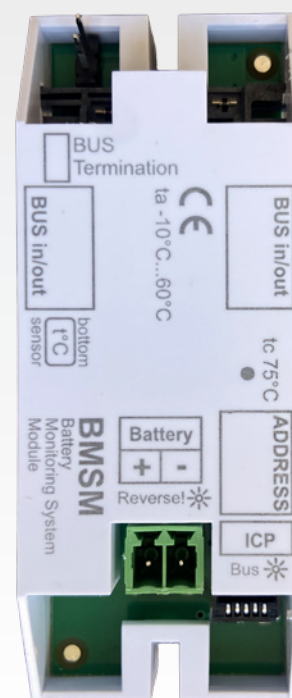

Technical specifications

Colour and material	RAL 9003 - PC
Insulation class	II
Operating temperature	-10 °C to +60 °C
Mounting	Inside mounting
Weight	Approx. 0.065 kg
Protection rating	IP20
Dimensions (H x W x D)	78 x 30 x 20 mm

NRG+ / NRG

Luminaires

The Exilux LPS and CPS systems are complementary and offer a professional emergency product range divided into two product families:

NRG+

NRG+ Series (with LPS or CPS central communication)

The NRG+ line offers advanced emergency lighting and signage with integrated communication to the CPS central monitoring system.

Designed for high-reliability environments, these products ensure compliance with safety regulations while providing real-time status updates and remote diagnostics. Ideal for large facilities, commercial buildings, and industrial sites where centralised control and monitoring are essential.

Key features:

- Centralised monitoring via LPS or CPS communication
- Automatic testing and fault reporting via LPS or CPS communication
- High-efficiency LED technology for optimal visibility
- Compliant with BS EN 60598-2-22, BS EN 1838, and other relevant standards

NRG

NRG Series (circuit monitoring)

The NRG range provides reliable emergency lighting and exit signage in a standalone configuration, perfect for smaller installations or locations where central monitoring is not required. These units ensure safety during power outages with robust performance and easy maintenance.

Key features:

- Independent operation with no central communication needed
- Energy-efficient LED illumination
- Durable construction for long-term reliability
- Compliant with BS EN 60598-2-22, BS EN 1838, and other relevant standards

Both NRG+ and NRG products are engineered for maximum safety, durability, and ease of installation, making them ideal for evacuation routes, emergency exits, and hazard identification.

Brighter ideas.



exilux

+44 (0) 1698 844700 • hello@exilux.co.uk • www.exilux.co.uk

Suite 45, Grovewood Business Centre, Wren Court, Strathclyde Business Park, Bellshill ML4 3NQ